

Alcatel 7300 ASAM

ATM Subscriber Access Multiplexer **Public Disclosure Document**

Final

Interface Specification
ASAM Release 4.2

May 22, 2003



Status Final

Change Note

Short Title Network Disclosure

All rights reserved. Passing on and copying of this document, use and communication of its content not permitted without written authorization from Alcatel.

Contents

1.	Preface.....	5
1.1.	Referenced Documents.....	5
1.2.	Abbreviations.....	6
2.	Overview.....	7
3.	DSL Interface Characteristics.....	10
3.1.	ADSL above POTS frequency spectrum usage.....	10
3.2.	ADSL over ISDN frequency spectrum usage.....	10
3.3.	SHDSL frequency spectrum usage.....	11
3.4.	DSL Interfaces available at the ASAM.....	12
4.	ADSL above POTS: G.992.1 Annex A.....	13
4.1.	General.....	13
4.2.	Transport capacity.....	13
4.3.	Framing Modes.....	14
4.4.	Network Timing Reference.....	14
5.	ADSL above POTS: G.992.2 Annex A/B.....	15
5.1.	General.....	15
5.2.	Transport capacity.....	15
5.3.	Network Timing Reference.....	15
6.	ADSL above POTS: G.992.2 Annex C.....	17
6.1.	General.....	17
6.2.	Transport capacity.....	17
6.3.	Network Timing Reference.....	17
7.	ADSL above POTS: T1.413.....	18
7.1.	General.....	18
7.2.	Transport capacity.....	18
7.3.	Framing Modes.....	19
7.4.	Network Timing Reference.....	19
8.	ADSL above ISDN: G.992.1 Annex B.....	20
8.1.	General.....	20
8.2.	Transport capacity.....	20
8.3.	Framing Modes.....	20
8.4.	Network Timing Reference.....	21
9.	ADSL above ISDN: ETS 101 388.....	22
9.1.	General.....	22
9.2.	Transport capacity.....	22
9.3.	Framing Modes.....	23
9.4.	Network Timing Reference.....	23
10.	SHDSL: G.991.2 Annex A.....	24
10.1.	General.....	24
10.2.	Transport capacity.....	24
10.3.	Network Timing Reference.....	24
11.	SHDSL: G.991.2 Annex B.....	25
11.1.	General.....	25
11.2.	Transport capacity.....	25
11.3.	Network Timing Reference.....	25
	Annex A: ATM Layer Interoperability.....	26
A.1	Referenced Documents.....	28
A.2	PMD & TC Layers.....	29

A.3	ATM Cell Header Format.....	29
A.4	Traffic Control & Congestion Control	31
A.5	UNI Configuration.....	32
A.6	UNI Signalling.....	32
Annex B: IP Layer Interoperability		33
Annex C: Voice-over-DSL Interoperability		34
C.1	Referenced Documents.....	34
C.2	Voice-over-DSL with CAS signalling.....	34
C.3	Voice-over-DSL with CCS signalling.....	34

1. Preface

The Alcatel 7300 ATM Subscriber Access Multiplexer (ASAM) is an access system for any ATM-based Broadband ISDN (BB-ISDN) switching fabric. The system delivers POTS and ADSL services to subscribers over the widely installed single metallic pair subscriber loop base.

This document specifies the DSL physical layer interface based on:

- ANSI Standard T1.413 [1];
- ETSI Technical Specification ETS 101 388 [2];
- ITU-T Recommendation G.992.1 [3];
- ITU-T Recommendation G.992.2 [4];
- ITU-T Recommendation G.994.1 [5];
- ITU-T Recommendation G.991.2 [6];
- ETSI Technical Specification ETS 101 524 [7].

Also annexes are added, describing:

- Annex A: ATM layer interface specification;
- Annex B: IP layer interface specification;
- Annex C: VoDSL interface specification.

This document provides the specification of the digital subscriber line interface. It refers to publicly available standards wherever possible. The xTU-C transmitter characteristics are described as they apply to the Alcatel 7300 ASAM central office and remote (e.g., Remote Access Multiplexer and cabinet-based ASAM) equipment.

The xTU-R transmitter requirements are specified with respect to interoperability with the Alcatel xTU-C. xTU-C characteristics and xTU-R requirements that may affect interoperability of the Alcatel xTU-C with an xTU-R are highlighted in this document.

1.1. Referenced Documents

The following documents are referenced:

- [1] ANSI Standard T1.413-1998, “Network and Customer Installation Interfaces – Asymmetrical Digital Subscriber Line (ADSL) Metallic Interface”, publication by the ANSI.
- [2] ETSI Technical Specification ETS 101 388, “Access transmission systems on metallic access cables; Asymmetric Digital Subscriber Line (ADSL) - Coexistence of ADSL and ISDN-BA on the same pair [ANSI T1.413-1998, modified]”, November 1998.

-
- [3] ITU-T Recommendation G.992.1, “*Asymmetrical Digital Subscriber Line (ADSL) Transceivers*”, publication by the ITU-T, 1999.
 - [4] ITU-T Recommendation G.992.2, “*Splitterless Asymmetrical Digital Subscriber Line (ADSL) Transceivers*”, publication by the ITU-T, 1999.
 - [5] ITU-T Recommendation G.994.1, “*Handshake Procedures for Asymmetrical Digital Subscriber Line (ADSL) Transceivers*”, publication by the ITU-T, 1999 and 2001.
 - [6] ITU-T Recommendation G.991.2, “*Single-Pair High Speed Digital Subscriber Line (SHDSL) Transceivers*“, publication by the ITU-T, 2001.
 - [7] ETSI Technical Specification ETS 101 524, “*Symmetric single pair high bit rate digital subscriber line (SDSL) transmission system on metallic local lines*”, version 1.1.2, August 2001.

1.2. Abbreviations

The following abbreviations are used:

To be completed.

2. Overview

The Alcatel 7300 ASAM implements a new transport method for delivery of broadband information on ordinary subscriber twisted pairs. It uses advanced modulation/signal processing techniques to allow high-speed digital communications between the ASAM and a DSL modem at the customer's premises (residential, SOHO or business). Both asymmetric (ADSL) and symmetric (SHDSL) interfaces are available.

Figure 1 and Figure 2 show the general ADSL architectures and their interfaces (depending on the usage of a POTS SPLITTER at the entrance of the subscriber premises or not). The following main building blocks can be distinguished:

- ASAM with ADSL interface at the network side.
- ADSL Customer Premises Equipment (CPE) at the subscriber side.

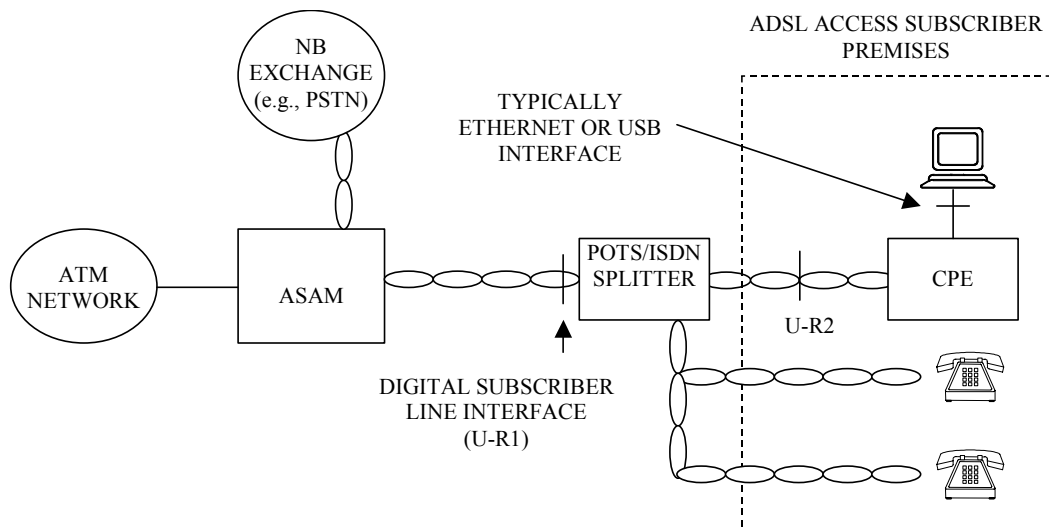

Figure 1 – ADSL Network Architecture (with POTS or ISDN Splitter).

In the case of Figure 1, a POTS or ISDN splitter is located at the entrance of the customer premises. A POTS splitter is used for operation of ADSL above POTS. An ISDN splitter is used for operation of ADSL above ISDN.

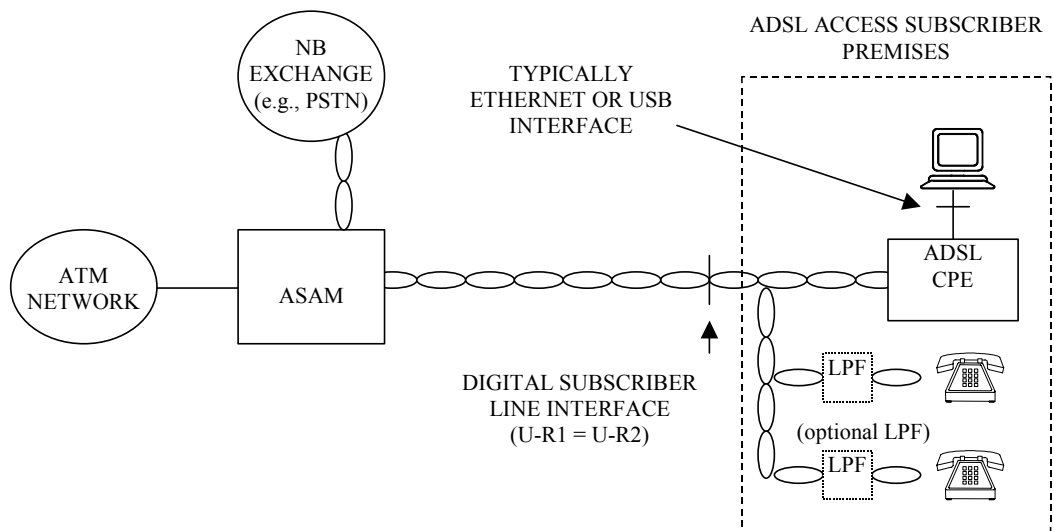

Figure 2 – Splitterless ADSL Network Architecture (without POTS SPLITTER).

In the case of Figure 2, no POTS SPLITTER is used at the entrance of the subscriber premises. Low Pass Filters (LPF) may be used instead to shield phone sets (or other voice band appliances) from interfering with the ADSL signal. Depending on the phone set characteristics, the absence of such LPF may have a severe impact on the achievable ADSL data rate.

The Figure 3 shows the general SHDSL architectures and interfaces. The following main building blocks can be distinguished:

- ASAM with SHDSL interface at the network side.
- SHDSL Customer Premises Equipment (CPE) at the subscriber side.

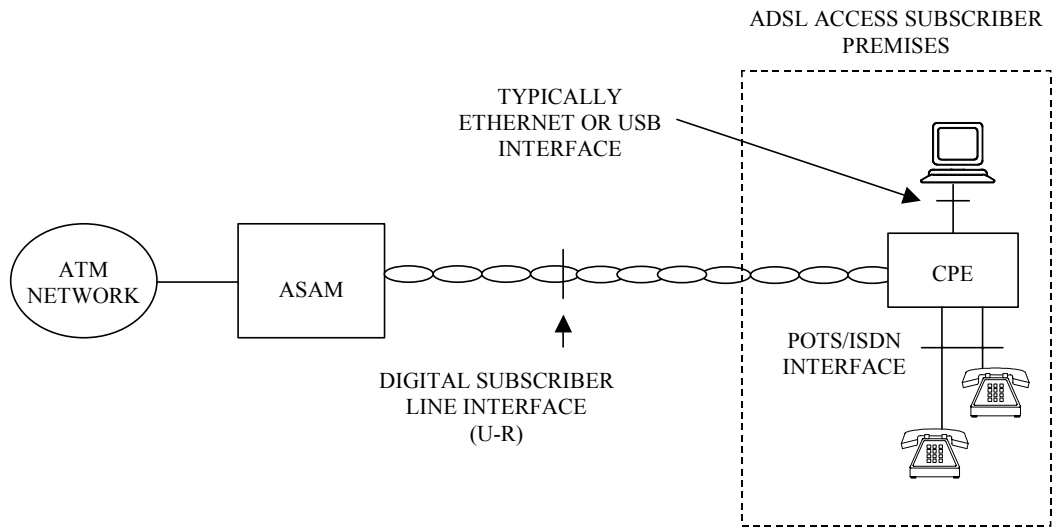

Figure 3 – SHDSL Network Architecture.

In the case of Figure 3, the SHDSL CPE is shown with example data and voice services. Alternatively, more business oriented interfaces may be provided, e.g., PABX interconnect.

3. DSL Interface Characteristics

3.1. ADSL above POTS frequency spectrum usage

The Digital Subscriber Line (DSL) interface carries the normal Plain Old Telephone Service (POTS) frequencies multiplexed with the upstream and downstream ADSL signals. The interface connects the ATU-R (in the CPE) to the ATU-C (in the ASAM) via the copper access network. Normal subscriber line wire is used for the connection.

The upstream and downstream signals are DMT modulated. A (qualitative) view of the DMT power spectrum density (PSD) used in the ADSL modem is shown in Figure 4.

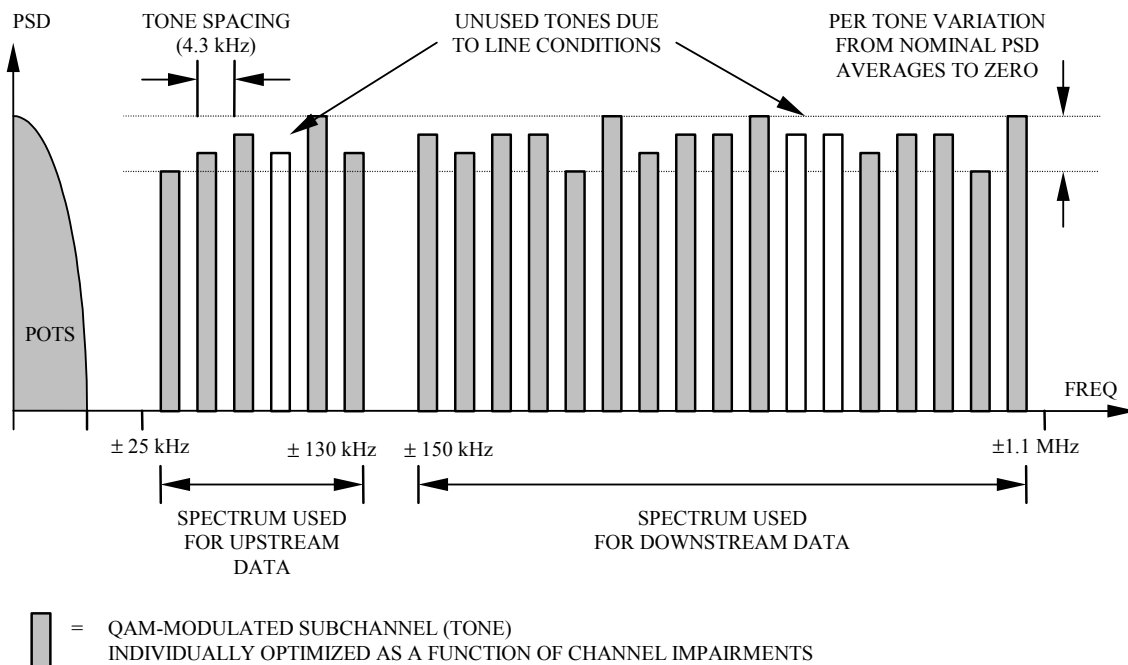

Figure 4 - DMT Spectrum Used in ADSL Modem

3.2. ADSL over ISDN frequency spectrum usage

The Digital Subscriber Line (DSL) interface carries the normal Integrated Services Digital Network (ISDN) signal frequencies multiplexed with the upstream and downstream ADSL signals. The interface connects the ATU-R (in the CPE) to the ATU-C (in the ASAM) via the copper access network. Normal subscriber line wire is used for the connection.

The upstream and downstream signals are DMT modulated. A (qualitative) view of the DMT power spectrum density (PSD) used in the ADSL modem is shown in Figure 5.

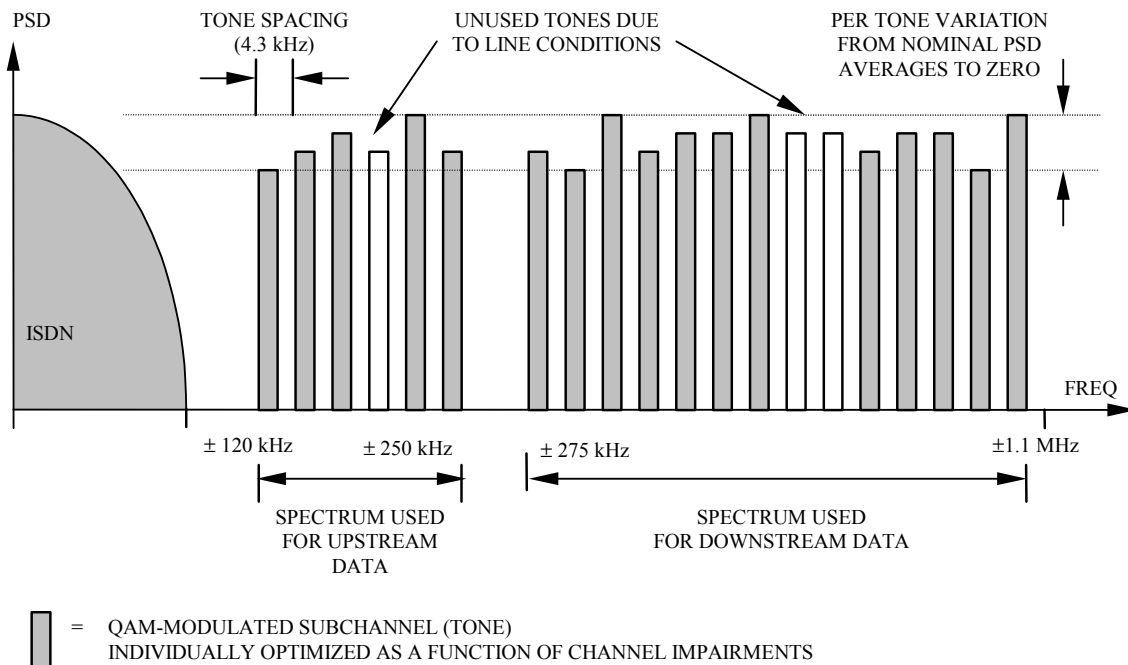

Figure 5 - DMT Spectrum Used in ADSL above ISDN Modem

3.3. SHDSL frequency spectrum usage

The Digital Subscriber Line (DSL) interface carries the upstream and downstream SHDSL signals. The downstream and upstream signals use the same frequency band. The frequency bandwidth depends on the data rate provided. Typically, the (3 dB down) bandwidth is the data rate divided by 6 (e.g., 384 kHz at 2.304 Mbit/s). The interface connects the STU-R (in the CPE) to the STU-C (in the ASAM) via the copper access network. Normal subscriber line wire is used for the connection.

The upstream and downstream signals are 16-TCPAM modulated. A view of the PAM power spectrum density (PSD) used in the SHDSL modem is shown in Figure 6. It shows how the bandwidth used by the SHDSL signal scales with the data rate.

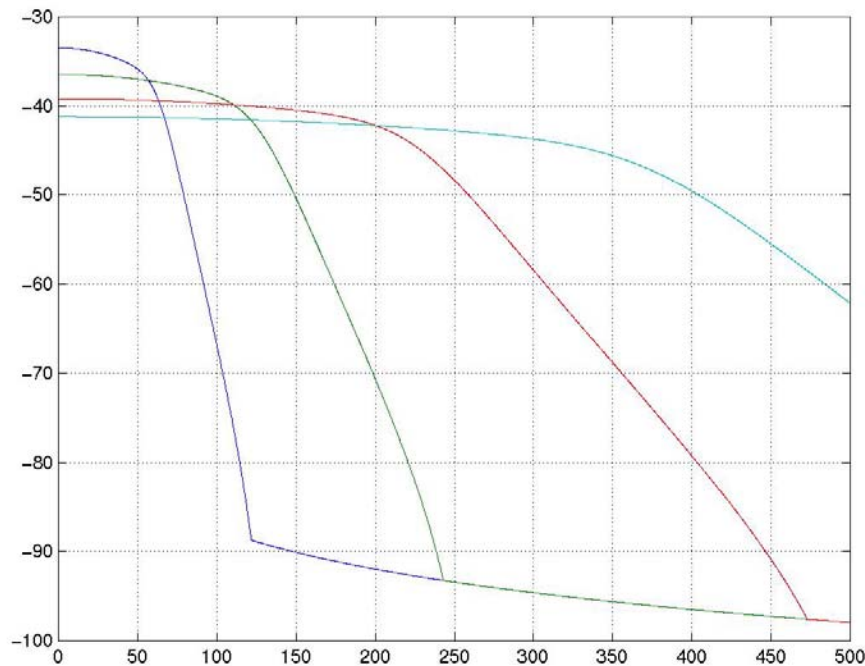

Figure 6 – SHDSL Spectrum for data rates 384, 768, 1536 and 2304 kbit/s.

3.4. DSL Interfaces available at the ASAM

The Alcatel ASAM supports the following ADSL operating modes:

- ADSL above POTS per ITU-T Rec. G.992.1 Annex A [3];
- ADSL above POTS per ITU-T Rec. G.992.2 Annex A/B [4];
- ADSL in TCM noise environment per ITU-T Rec. G.992.2 Annex C [4].
- ADSL above POTS per ANSI Standard T1.413 [1];
- ADSL above ISDN per ITU-T Rec. G.992.1 Annex B [3];
- ADSL above ISDN per ETSI Technical Spec. ETS 300 388 [2].

The Alcatel ASAM supports the following S(H)DSL operating modes:

- SHDSL for North America per ITU-T Rec. G.991.2 Annex A [6].
- SHDSL for Europe per ITU-T Rec. G.991.2 Annex B [6].

The ATU-C characteristics and the ATU-R requirements to interoperate with the ATU-C are described in separate sections for each of these operating modes.

4. ADSL above POTS: G.992.1 Annex A

The ITU-T Recommendation G.992.1 is also known as G.dmt.

The ATU-C startup procedure supports both the G.994.1 Handshake Procedures [5] and the T1.413-1998 Initialization Procedure [1].

In case the ATU-R alternates [5] and [1] according to G.994.1 Annex A, the ATU-C gives priority to G.994.1 Handshake Procedures and a subsequent G.992.x operating mode.

In case both the ATU-C and the ATU-R support the G.992.1 and G.992.2 operating modes, the ATU-C (when selecting the operating mode) gives priority to the G.992.1 operating mode.

4.1. General

The U-C interface is compliant with G.992.1 Annex A [3] (including G.994.1 [5]), unless explicitly stated in this section.

The U-R interface shall be compliant with G.992.1 Annex A [3] (including G.994.1 [5]).

The U-C interface is an ATM cell-based interface. The ATU-C is configured for ATM transport and complies with sections 5.1.2, 6.2, and 7.2 of G.992.1 [3].

The U-R interface shall be an ATM cell-based interface. The ATU-R shall be configured for ATM transport and shall comply with sections 5.2.2, 6.2, and 8.2 of G.992.1 [3].

4.2. Transport capacity

The transport capacity of the ATU-C complies with section 6.2 of G.992.1 [3]. It supports downstream transmission at all multiples of 32 kb/s up to a net data rate of 6.144 Mb/s, and upstream reception at all multiples of 32 kb/s up to a net data rate of 640 kb/s upstream.

The transport capacity of the ATU-R shall comply with section 6.2 of G.992.1 [3]. It shall support downstream reception at all multiples of 32 kb/s up to a net data rate of 6.144 Mb/s, and upstream transmission at all multiples of 32 kb/s up to a net data rate of 640 kb/s.

The maximum downstream transport capacity of the ATU-C implementation is $255 \times 32 = 8160$ kb/s (total data rate). The actual downstream transport capacity depends upon the line characteristics measured at modem initialization and the implementation limitations of the ATU-R. The ADSL system overhead depends on the modem configuration and can be as low as 32 kb/s.

4.3. Framing Modes

The framing modes supported by the ATU-C are compliant with G.992.1 [3], with the exception of the support of framing mode 0. The bit stuffing mechanism which may be activated in framing mode 0 provides data rate decoupling. The same functionality is achieved through ATM Idle Cell insertion. Other framing mode 0 functionalities are also provided in framing mode 1. Framing mode 1 is supported by the ATU-C. Not supporting framing mode 0 does not affect interoperability with an ATU-R compliant with G.992.1 [3]. However, interoperability with a (non G.992.1 compliant) ATM-over-STM ATU-R is not assured (see G.992.1 [3] section 7.2.4).

4.4. Network Timing Reference

The ATU-C inserts the Network Timing Reference in the ADSL frame, as specified in G.992.1 [3]. The ATU-R may recover the Network Timing Reference from that information.

NOTE – On the Standard Density Hardware Platform, the ATU-C does not insert the Network Timing Reference. The NTR bit in C-MSG1 is always coded “0”. The downstream indicator bits 23–20 are always coded “1111”.

4.5. Data on pilot subcarrier 64

The ITU-T Recommendation G.992.1 specifies that no data shall be carried on the downstream pilot subcarrier 64. However, the ATU-C may indicate in the G.994.1 non-standard information field (NSIF) that it supports modulation of data on the downstream pilot subcarrier 64. If the ATU-R indicates the same, then data modulation on the downstream pilot subcarrier 64 is enabled. The G.994.1 NSIF syntax is defined in Annex A.

5. ADSL above POTS: G.992.2 Annex A/B

The ITU-T Recommendation G.992.2 is also known as G.lite.

The ATU-C startup procedure supports both the G.994.1 Handshake Procedures [5] and the T1.413-1998 Initialization Procedure [1].

In case the ATU-R alternates [5] and [1] according to G.994.1 Annex A, the ATU-C gives priority to G.994.1 Handshake Procedures and a subsequent G.992.x operating mode.

In case both the ATU-C and the ATU-R support the G.992.1 and G.992.2 operating modes, the ATU-C (when selecting the operating mode) gives priority to the G.992.1 operating mode.

5.1. General

The U-C interface is compliant with G.992.2 Annex A/B [4] (including G.994.1 [5]).

The U-R interface shall be compliant with G.992.2 Annex A/B [4] (including G.994.1 [5]).

5.2. Transport capacity

The transport capacity of the ATU-C complies with section 5 of G.992.2 [4]. It supports downstream transmission at all multiples of 32 kb/s up to a net data rate of 1.536 Mb/s, and upstream reception at all multiples of 32 kb/s up to a net data rate of 512 kb/s upstream.

The transport capacity of the ATU-R shall comply with section 5 of G.992.2 [4]. It shall support downstream reception at all multiples of 32 kb/s up to a net data rate of 1.536 Mb/s, and upstream transmission at all multiples of 32 kb/s up to a net data rate of 512 kb/s.

The maximum downstream transport capacity of the ATU-C implementation is $255 \times 32 = 8160$ kb/s (total data rate). The actual downstream transport capacity depends upon the line characteristics measured at modem initialization and the implementation limitations of the ATU-R. The ADSL system overhead depends on the modem configuration and can be as low as 32 kb/s.

5.3. Network Timing Reference

The ATU-C inserts the Network Timing Reference in the ADSL frame, as specified in G.992.2 [4]. The ATU-R may recover the Network Timing Reference from that information.

NOTE – On the Standard Density Hardware Platform, the ATU-C does not insert the Network Timing Reference. The NTR bit in C-MSG1 is always coded “0”. The downstream indicator bits 23–20 are always coded “1111”.

5.4. Data on pilot subcarrier 64

The ITU-T Recommendation G.992.1 specifies that no data shall be carried on the downstream pilot subcarrier 64. However, the ATU-C may indicate in the G.994.1 non-standard information field (NSIF) that it supports modulation of data on the downstream pilot subcarrier 64. If the ATU-R indicates the same, then data modulation on the downstream pilot subcarrier 64 is enabled. The G.994.1 NSIF syntax is defined in Annex A.

6. ADSL above POTS: G.992.2 Annex C

The ITU-T Recommendation G.992.2 is also known as G.lite.

6.1. General

The U-C interface is compliant with G.992.2 Annex C [4] (including G.994.1 [5]).

The U-R interface shall be compliant with G.992.2 Annex C [4] (including G.994.1 [5]).

6.2. Transport capacity

The transport capacity of the ATU-C complies with section 5 of G.992.2 [4]. It supports downstream transmission at all multiples of 32 kb/s up to a net data rate of 1.536 Mb/s, and upstream reception at all multiples of 32 kb/s up to a net data rate of 512 kb/s upstream.

The transport capacity of the ATU-R shall comply with section 5 of G.992.2 [4]. It shall support downstream reception at all multiples of 32 kb/s up to a net data rate of 1.536 Mb/s, and upstream transmission at all multiples of 32 kb/s up to a net data rate of 512 kb/s.

The maximum downstream transport capacity of the ATU-C implementation is $255 \times 32 = 8160$ kb/s (total data rate). The actual downstream transport capacity depends upon the line characteristics measured at modem initialization and the implementation limitations of the ATU-R. The ADSL system overhead depends on the modem configuration and can be as low as 32 kb/s.

6.3. Network Timing Reference

The ATU-C inserts the Network Timing Reference in the ADSL frame, as specified in G.992.2 [4]. The ATU-R may recover the Network Timing Reference from that information.

NOTE – On the Standard Density Hardware Platform, the ATU-C does not insert the Network Timing Reference. The NTR bit in C-MSG1 is always coded “0”. The downstream indicator bits 23–20 are always coded “1111”.

7. ADSL above POTS: T1.413

The ANSI Standard T1.413-1998 is also known as T1.413 Issue 2.

The ATU-C startup procedure supports both the G.994.1 Handshake Procedures [5] and the T1.413-1998 Initialization Procedure [1].

In case the ATU-R alternates [5] and [1] according to G.994.1 Annex A, the ATU-C gives priority to G.994.1 Handshake Procedures and a subsequent G.992.x operating mode.

In case both the ATU-C and the ATU-R support the G.992.1 and G.992.2 operating modes, the ATU-C (when selecting the operating mode) gives priority to the G.992.1 operating mode.

7.1. General

The U-C interface is compliant with T1.413 [1], unless explicitly stated in this section.

The U-R interface shall be compliant with T1.413 [1].

The U-C interface is an ATM cell-based interface. The ATU-C is configured for ATM transport and complies with sections 4.2.2, 5.2, and 6.2 of T1.413 [1].

The U-R interface shall be an ATM cell-based interface. The ATU-R shall be configured for ATM transport and shall comply with sections 4.3.2, 5.2, and 7.2 of T1.413 [1].

7.2. Transport capacity

The transport capacity of the ATU-C complies with section 5.2 of T1.413 [1]. It supports downstream transmission at all multiples of 32 kb/s up to a net data rate of 6.144 Mb/s, and upstream reception at all multiples of 32 kb/s up to a net data rate of 640 kb/s upstream.

The transport capacity of the ATU-R shall comply with section 5.2 of T1.413 [1]. It shall support downstream reception at all multiples of 32 kb/s up to a net data rate of 6.144 Mb/s, and upstream transmission at all multiples of 32 kb/s up to a net data rate of 640 kb/s.

The maximum downstream transport capacity of the ATU-C implementation is $255 \times 32 = 8160$ kb/s (total data rate). The actual downstream transport capacity depends upon the line characteristics measured at modem initialization and the implementation limitations of the ATU-R. The ADSL system overhead depends on the modem configuration and can be as low as 32 kb/s.

7.3. Framing Modes

The framing modes supported by the ATU-C are compliant with T1.413 [1], with the exception of the support of framing mode 0. The bit stuffing mechanism which may be activated in framing mode 0 provides data rate decoupling. The same functionality is achieved through ATM Idle Cell insertion. Other framing mode 0 functionalities are also provided in framing mode 1. Framing mode 1 is supported by the ATU-C. Not supporting framing mode 0 does not affect interoperability with an ATU-R compliant with T1.413 [1]. However, interoperability with a (non T1.413 compliant) ATM-over-STM ATU-R is not assured (see T1.413 [1] section 6.2.4).

7.4. Network Timing Reference

The ATU-C inserts the Network Timing Reference in the ADSL frame, as specified in T1.413 [1]. The ATU-R may recover the Network Timing Reference from that information.

NOTE – On the Standard Density Hardware Platform, the ATU-C does not insert the Network Timing Reference. The NTR bit in C-MSG1 is always coded “0”. The downstream indicator bits 23–20 are always coded “1111”.

8. ADSL above ISDN: G.992.1 Annex B

The ITU-T Recommendation G.992.1 is also known as G.dmt.

The ATU-C startup procedure supports both the G.994.1 Handshake Procedures [5] and the ETS 101 388 Initialization Procedure [2].

In case the ATU-R alternates [5] and [2] according to G.994.1 Annex A, the ATU-C gives priority to G.994.1 Handshake Procedures and a subsequent G.992.x operating mode.

8.1. General

The U-C interface is compliant with G.992.1 Annex B [3] (including G.994.1 [5]), unless explicitly stated in this section.

The U-R interface shall be compliant with G.992.1 Annex B [3] (including G.994.1 [5]).

The U-C interface is an ATM cell-based interface. The ATU-C is configured for ATM transport and complies with sections 5.1.2, 6.2, and 7.2 of G.992.1 [3].

The U-R interface shall be an ATM cell-based interface. The ATU-R shall be configured for ATM transport and shall comply with sections 5.2.2, 6.2, and 8.2 of G.992.1 [3].

8.2. Transport capacity

The transport capacity of the ATU-C complies with section 6.2 of G.992.1 [3]. It supports downstream transmission at all multiples of 32 kb/s up to a net data rate of 6.144 Mb/s, and upstream reception at all multiples of 32 kb/s up to a net data rate of 640 kb/s upstream.

The transport capacity of the ATU-R shall comply with section 6.2 of G.992.1 [3]. It shall support downstream reception at all multiples of 32 kb/s up to a net data rate of 6.144 Mb/s, and upstream transmission at all multiples of 32 kb/s up to a net data rate of 640 kb/s.

The maximum downstream transport capacity of the ATU-C implementation is $255 \times 32 = 8160$ kb/s (total data rate). The actual downstream transport capacity depends upon the line characteristics measured at modem initialization and the implementation limitations of the ATU-R. The ADSL system overhead depends on the modem configuration and can be as low as 32 kb/s.

8.3. Framing Modes

The framing modes supported by the ATU-C are compliant with G.992.1 [3], with the exception of the support of framing mode 0. The bit stuffing mechanism which may be activated in framing mode 0 provides data rate decoupling. The same functionality is achieved through ATM Idle Cell insertion. Other framing mode 0 functionalities are also provided in framing mode 1. Framing mode 1 is supported by the ATU-C. Not supporting framing mode 0 does not affect interoperability with an ATU-R compliant with G.992.1 [3]. However, interoperability with a (non G.992.1 compliant) ATM-over-STM ATU-R is not assured (see G.992.1 [3] section 7.2.4).

8.4. Network Timing Reference

The ATU-C inserts the Network Timing Reference in the ADSL frame, as specified in G.992.1 [3]. The ATU-R may recover the Network Timing Reference from that information.

NOTE – On the Standard Density Hardware Platform, the ATU-C does not insert the Network Timing Reference. The NTR bit in C-MSG1 is always coded “0”. The downstream indicator bits 23–20 are always coded “1111”.

9. ADSL above ISDN: ETS 101 388

The ETS 101 388 Technical Specification is an adaptation of the ANSI ADSL over POTS Standard T1.413-1998 [1] for the transport of ADSL over ISDN.

The ATU-C startup procedure supports both the G.994.1 Handshake Procedures [5] and the T1.413-1998 Initialization Procedure [1].

In case the ATU-R alternates [5] and [1] according to G.994.1 Annex A, the ATU-C gives priority to G.994.1 Handshake Procedures and a subsequent G.992.x operating mode.

9.1. General

The U-C interface is compliant with ETS 101 388 [2], unless explicitly stated in this section.

The U-R interface shall be compliant with ETS 101 388 [2].

The U-C interface is an ATM cell-based interface. The ATU-C is configured for ATM transport and complies with ETS 101 388 [2], which references sections 4.2.2, 5.2, and 6.2 of T1.413 [1].

The U-R interface shall be an ATM cell-based interface. The ATU-R shall be configured for ATM transport and shall comply with ETS 101 388 [2], which references sections 4.3.2, 5.2, and 7.2 of T1.413 [1].

9.2. Transport capacity

The transport capacity of the ATU-C complies with ETS 101 388 [2], which references section 5.2 of T1.413 [1]. It supports downstream transmission at all multiples of 32 kb/s up to a net data rate of 6.144 Mb/s, and upstream reception at all multiples of 32 kb/s up to a net data rate of 640 kb/s upstream.

The transport capacity of the ATU-R shall comply with ETS 101 388 [2], which references section 5.2 of T1.413 [1]. It shall support downstream reception at all multiples of 32 kb/s up to a net data rate of 6.144 Mb/s, and upstream transmission at all multiples of 32 kb/s up to a net data rate of 640 kb/s.

The maximum downstream transport capacity of the ATU-C implementation is $255 \times 32 = 8160$ kb/s (total data rate). The actual downstream transport capacity depends upon the line characteristics measured at modem initialization and the implementation limitations of the ATU-R. The ADSL system overhead depends on the modem configuration and can be as low as 32 kb/s.

9.3. Framing Modes

The framing modes supported by the ATU-C are compliant with ETS 101 388 [2], which references T1.413 [1], with the exception of the support of framing mode 0. The bit stuffing mechanism which may be activated in framing mode 0 provides data rate decoupling. The same functionality is achieved through ATM Idle Cell insertion. Other framing mode 0 functionalities are also provided in framing mode 1. Framing mode 1 is supported by the ATU-C. Not supporting framing mode 0 does not affect interoperability with an ATU-R compliant with ETS 101 388 [2]. However, interoperability with a (non ETS 101 388 [2] compliant) ATM-over-STM ATU-R is not assured (see ETS 101 388 [2], which references T1.413 [1] section 6.2.4).

9.4. Network Timing Reference

The ATU-C inserts the Network Timing Reference in the ADSL frame, as specified in ETR 101 388 [2] (referencing T1.413 [1]). The ATU-R may recover the Network Timing Reference from that information.

NOTE – On the Standard Density Hardware Platform, the ATU-C does not insert the Network Timing Reference. The NTR bit in C-MSG1 is always coded “0”. The downstream indicator bits 23–20 are always coded “1111”.

10. SHDSL: G.991.2 Annex A

10.1. General

The U-C interface is compliant with G.991.2 Annex A [6], unless explicitly stated in this section. The G.991.2 Annex A operating mode is activated through the G.994.1 Handshake Procedure [5].

The U-R interface shall be compliant with G.991.2 Annex A [6].

The U-C interface is an ATM cell-based interface. The STU-C is configured for ATM transport and complies with section E.9 of G.991.2 [6].

The U-R interface shall be an ATM cell-based interface. The STU-R shall be configured for ATM transport and shall comply with section E.9 of G.991.2 [6].

10.2. Transport capacity

The transport capacity of the STU-C complies with section 5 of G.991.2 [6]. It supports symmetric data rates at all multiples of 64 kbit/s, from 192 kbit/s up to a net data rate of 2.304 Mbit/s. The data rate may be fixed or limited to within a range of data rates through the Central Office MIB.

The transport capacity of the STU-R shall comply with section 5 of G.991.2 [6]. It shall support one or more symmetric data rates at multiples of 64 kbit/s, from 192 kbit/s up to a net data rate of 2.304 Mbit/s.

10.3. Network Timing Reference

The STU-C operates in synchronous mode. The SHDSL frame period and symbol clock are locked to the network clock. The STU-R may recover the Network Timing Reference from either the SHDSL frame period or the SHDSL symbol clock.

11. SHDSL: G.991.2 Annex B

Operation according to G.992.1 Annex B [6] is identical to operation according to ETSI SDSL ETS 101 524 [7]. Both operating modes are activated in exactly the same way through G.994.1 Handshake Procedures [5]. Therefore, the STU-R cannot distinguish the two operating modes. The STU-R interface requirements are identical for both operating modes and described from G.992.1 Annex B perspective below.

11.1. General

The U-C interface is compliant with G.991.2 Annex B [6], unless explicitly stated in this section. The G.991.2 Annex B operating mode is activated through the G.994.1 Handshake Procedure [5].

The U-R interface shall be compliant with G.991.2 Annex B [6].

The U-C interface is an ATM cell-based interface. The STU-C is configured for ATM transport and complies with section E.9 of G.991.2 [6].

The U-R interface shall be an ATM cell-based interface. The STU-R shall be configured for ATM transport and shall comply with section E.9 of G.991.2 [6].

11.2. Transport capacity

The transport capacity of the STU-C complies with section 5 of G.991.2 [6]. It supports symmetric data rates at all multiples of 64 kbit/s, from 192 kbit/s up to a net data rate of 2.304 Mbit/s. The data rate may be fixed or limited to within a range of data rates through the Central Office MIB.

The STU-C also supports the symmetric data rate of 2.312 Mbit/s for transport of the 2048 kbit/s E1 service over AAL1 ATM. When configured in this mode, the STU-C advertises a single data rate in the G.994.1 handshake [5], indicating ATM mode with $n=36$ and $i=1$.

The transport capacity of the STU-R shall comply with section 5 of G.991.2 [6]. It shall support one or more symmetric data rates at multiples of 64 kbit/s, from 192 kbit/s up to a net data rate of 2.312 Mbit/s.

11.3. Network Timing Reference

The STU-C operates in synchronous mode. The SHDSL frame period and symbol clock are locked to the network clock. The STU-R may recover the Network Timing Reference from either the SHDSL frame period or the SHDSL symbol clock.

Non-standard information field – {SPar(1)} coding

SPar(1)s Octet 1/1	8	7	6	5	4	3	2	1
G.992.1 – Annex A	x	x	x	x	x	x	x	1
Reserved	x	x	x	x	x	x	1	x
Reserved	x	x	x	x	x	1	x	x
G.992.2 – Annex A/B	x	x	x	x	1	x	x	x
Reserved	x	x	x	1	x	x	x	x
Reserved	x	x	1	x	x	x	x	x
Reserved	x	1	x	x	x	x	x	x
No parameters in this octet	x	0	0	0	0	0	0	0

Non-standard information field – G.992.1 Annex A {NPar(2)} coding – Octet 1

NPar(1)s Octet 1/1	8	7	6	5	4	3	2	1
Reserved	x	x	x	x	x	x	x	1
Reserved	x	x	x	x	x	x	1	x
Reserved	x	x	x	x	x	1	x	x
Reserved	x	x	x	x	1	x	x	x
Reserved	x	x	x	1	x	x	x	x
Reserved	x	x	1	x	x	x	x	x
No parameters in this octet	x	x	0	0	0	0	0	0

Non-standard information field – G.992.1 Annex A {NPar(2)} coding – Octet 2

NPar(2)s Octet 2/2	8	7	6	5	4	3	2	1
Reserved	x	x	x	x	x	x	x	1
Reserved	x	x	x	x	x	x	1	x
DPM	x	x	x	x	x	1	x	x
Reserved	x	x	x	x	1	x	x	x
Reserved	x	x	x	1	x	x	x	x
Reserved	x	x	1	x	x	x	x	x
No parameters in this octet	x	x	0	0	0	0	0	0

Non-standard information field – G.992.2 Annex A {NPar(2)} coding – Octet 1

NPar(1)s Octet 1/1	8	7	6	5	4	3	2	1
Reserved	x	x	x	x	x	x	x	1
Reserved	x	x	x	x	x	x	1	x
Reserved	x	x	x	x	x	1	x	x
Reserved	x	x	x	x	1	x	x	x
Reserved	x	x	x	1	x	x	x	x
Reserved	x	x	1	x	x	x	x	x
No parameters in this octet	x	x	0	0	0	0	0	0

Non-standard information field – G.992.2 Annex A {NPar(2)} coding – Octet 2

NPar(2)s Octet 2/2	8	7	6	5	4	3	2	1
Reserved	x	x	x	x	x	x	x	1
Reserved	x	x	x	x	x	x	1	x
DPM	x	x	x	x	x	1	x	x
Reserved	x	x	x	x	1	x	x	x
Reserved	x	x	x	1	x	x	x	x
Reserved	x	x	1	x	x	x	x	x
No parameters in this octet	x	x	0	0	0	0	0	0

Annex B: ATM Layer Interoperability

This annex is published by Alcatel to provide a technical description of the ATM layer of the user network interface. It is intended as a guideline for third-party ATM systems to successfully interoperate with the ASAM.

For describing the ATM interoperability, the ATM reference model is used to specify the various aspects. It is assumed the reader is familiar with this model and its terminology.

All features are supported in both upstream and downstream directions unless otherwise stated.

B.1 Referenced Documents

[ITU-T-I.361] ITU-T Recommendation I.361 ISDN Overall Network Aspects and Functions (11/95). B-ISDN ATM Layer Specification.

[ITU-T-I.371] ITU-T Recommendation I.371 ISDN Traffic Control and Congestion Control (08/96). B-ISDN ATM Layer Specification.

[ITU-T-I.432] ITU-T Recommendation I.432.1 - B-ISDN User-Network Interface - Physical Layer Specification: General Characteristics, August 1996.

[ITU-T-I.610] ITU-T Recommendation I.610 - B-ISDN Operation and Maintenance Principles and Functions (11/95).

[ITU-T-I.731] ITU-T Recommendation I.731- B-ISDN Types and general characteristics of ATM equipment (03/96).

[ITU-T-I.732] ITU-T Recommendation I.732- B-ISDN Functional characteristics of ATM equipment (03/96).

[ATMF-3.1] ATM Forum AF-UNI-0010.002 - ATM User-Network Interface Specification V3.1.

[ATMF-Traffic] ATM Forum AF-TM-0056.000 - Traffic Management Specification Version 4.0.

The base documents for ATM layer specifications are [ITU-T-I.731], [ITU-T-I.732], [ITU-T-I.361] and [ATMF-3.1].

B.2 PMD & TC Layers

The functions listed below are typically Physical Medium Dependent and Transmission Convergence Sublayer functions:

- Cell Stream mapping/demapping
- Cell Delineation
- Payload Scrambling
- HEC Processing
- Cell Rate Decoupling

These functions interact directly with the underlying ADSL layer, which is almost independent of the processing of ATM cells. Therefore, this specific interoperability information is described in the documents referenced in the ADSL interface description.

B.3 ATM Cell Header Format

Cell Format

The ATM cell format is compliant with Recommendation [ITU-T-I.361].

This implies the cell structure complies with the generic ATM cell structure as defined in [ITU-T-I.361] Clause 2.1: Cell Structure.

The cell header coding scheme is of type ITU public **UNI** and complies to [ITU-T-I.361] Clause 2.2: Cell header format and encoding at UNI.

GFC Field

The GFC field coding is compliant with [ITU-T-I.361] Clause 2.2.2: Generic Flow Control field. Currently it is assumed that most CPE equipment connected to the ASAM acts as "uncontrolled equipment". According to [ITU-T-I.361] this implies:

- downstream: cells sourced by the ASAM will have their GFC bits set to 0;
- no action shall be taken by ASAM on GFC field settings of received cells, moreover, non-zero GFC bits shall be forced to zero for cells "in transit".

Routing field (VPI & VCI field)

The 24 bit routing field consists of 8 bits VPI and 16 bits VCI which is compliant with [ITU-T-I.361] UNI format.

For PVC's VPI values can range from 0 to 255 and VCI values from 0 to 65535. The actual number of bits in the VPI and VCI fields used for routing, are configured compliant with the rules defined in [ITU-T-I.361] Clause 2.2.3: Routing field (VPI/VCI).

The ASAM supports simultaneous use of SVC's and PVC's, however the restrictions below must be taken into account:

- for SVC operation one single VPI can be used which must be preconfigured by the operator:
 - this VPI value can range from 0 the maxVPI value. From the moment a single SVC is established all subsequent SVC's will be set-up with this VPC;
 - within this preconfigured SVC VPI, VCI values can range from 48 to maxVCI value;
- for PVC operation the VPI/VCI ranges below are possible:
 - VPI can range from 0 to maxVPI value;
 - VCI can range from 32 to maxVCI value.

VPI Field & VCI Field - Reserved VPI/VCI values

When processing cell headers, the ASAM takes the pre-assigned cell header values listed below into account:

- the pre-assigned cell header values for use by the physical layer at the UNI, [ITU-T-T.361] Table 1;
- the combinations of pre-assigned VPI, VCI, PTI and CLP values at the UNI [ITU-T-T.361] Table 2;

The ASAM will not source ATM cells on the pre-assigned VPI/VCI values at the UNI except for VPI 0 / VCI 5: Point-to-point signalling and VPI 0 / VCI 16: ILMI.

When configured as a VC Cross-Connect the Alcatel ASAM will discard all ATM cells arriving on the pre-assigned VPI/VCI values at the UNI. Except for VPI 0 / VCI 5: Point-to-point signalling and VPI 0 / VCI 16: ILMI.

PTI Field

The PTI field encoding/decoding is compliant to [ITU-T-I.361].

PTI field bit assignment:

- EFCI bit;
- AUU bit;
- F5 cells;
- RM cells;
- reserved cells.

AUU bit (ATM User to ATM User bit): the ASAM leaves the AUU bit untouched because it is AAL5 unaware.

EFCI bit (Explicit Forward Congestion Indication): EFCI marking is performed in the ASAM in

case of congestion.

OAM F5 cell indication bits:

- if the ASAM is configured as VP cross connect, the F5 cells are treated in a transparent manner independently of downstream or upstream direction;
- if the ASAM is configured as VC cross connect, F5 cells are silently discarded in both downstream and upstream direction;
- the ASAM will not source OAM F5 cells itself.

VC RM Cell indication bits:

- if the ASAM is configured as VP cross connect, the VC RM cells are treated in a transparent manner independently of downstream or upstream direction;
- if the ASAM is configured as VC cross connect, VC RM cells are silently discarded in both downstream and upstream direction;
- the ASAM will not source VC RM cells itself.

VC reserved cell indication bits:

- if the ASAM is configured as VP cross connect, the VC reserved cells are treated in a transparent manner independently of downstream or upstream direction;
- if the ASAM is configured as VC cross connect, VC reserved cells are silently discarded in both downstream and upstream direction;
- the ASAM will not source VC reserved cells itself.

B.4 Traffic Control & Congestion Control

The ASAM implements VP/VC UPC at the UNI to detect violations of negotiated traffic parameters and reacts appropriately to protect the QoS of other VPC's/VCC's.

If the ASAM is configured as a VP cross-connect, VP UPC can be performed on each VP connection.

If the ASAM is configured as a VC cross-connect, VC UPC can be performed on each VC connection.

Via configuration management following service classes can be configured:

- UBR .1
- CBR.1

For SVC operation, following service classes are supported:

-
- UBR .1
 - CBR.1
 - CBR.2
 - CBR.3

Whether traffic is conforming with the configured service class is checked via the GCRA algorithm which is defined in [ITU-T-I.371].

CLP Field

In downstream direction, the CLP bit setting is left untouched. In upstream, depending on the service class that is configured, the CLP bit is checked and modified according to the UPC rules. For UBR no policing is performed.

B.5 UNI Configuration

To be completed.

B.6 UNI Signalling

To be completed.

Annex C: IP Layer Interoperability

The Alcatel ASAM may integrate an IP Gateway to enable the Internet Access service. The IP Gateway operates as BroadBand Remote Access Server (BB-RAS).

To be completed.

Annex D: Voice-over-DSL Interoperability

The Alcatel ASAM may integrate a Voice Gateway (or be associated with a standalone Voice Gateway) to enable the voice-over-DSL service. The Voice Gateway provides the Broadband Loop Emulation Service, implementing voice over ATM.

The Alcatel Voice Gateway supports two different signalling interfaces. The signalling interface used is region dependent.

- Channel Associated Signalling (CAS) is supported for use e.g., in North America;
- Common Channel Signalling (CCS) is supported for use e.g., in Europe.

D.1 Referenced Documents

[BLES] ATM Forum AF-VMOA-0145.000, Voice and Multimedia Over ATM - Loop Emulation Service Using AAL2, July 2000.

[TR39] DSL Forum Technical Report 39, "Requirements for Voice over DSL", March 2001.

D.2 Voice-over-DSL with CAS signalling

The U-C interface is compliant with the Voice over DSL requirements listed in [TR39]. The implementation is compliant with the [BLES] specification, unless explicitly stated in this section. The U-C interface signalling is compliant with the CAS signalling option defined in the same document.

The U-R interface shall be compliant with the [BLES] specification and the CAS signalling option specified in that document.

D.3 Voice-over-DSL with CCS signalling

The U-C interface is compliant with the Voice over DSL requirements listed in [TR39]. The implementation is compliant with the [BLES] specification, unless explicitly stated in this section. The U-C interface signalling is compliant with the CCS signalling option defined in the same document.

The U-R interface shall be compliant with the [BLES] specification and the CCS signalling option specified in that document.